

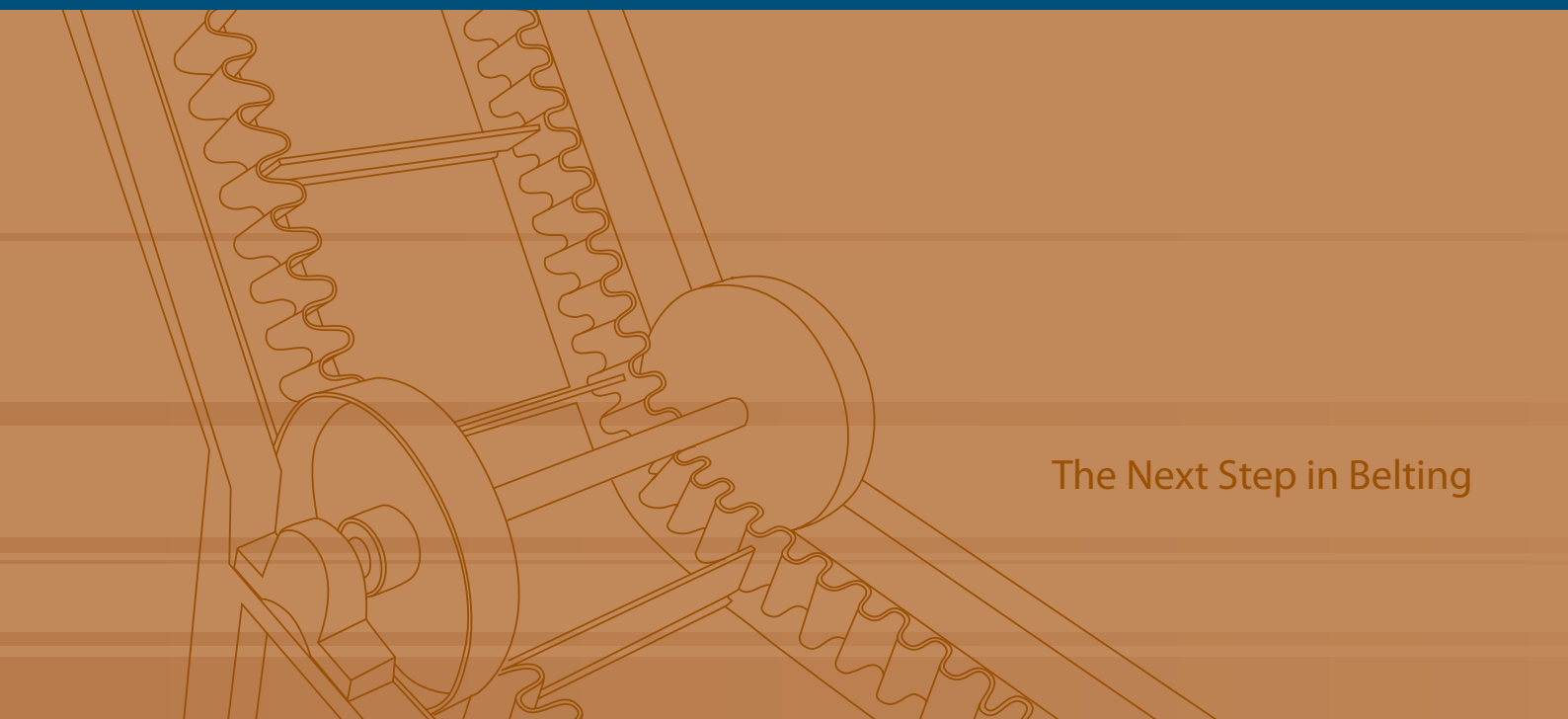

Special Sidewalls

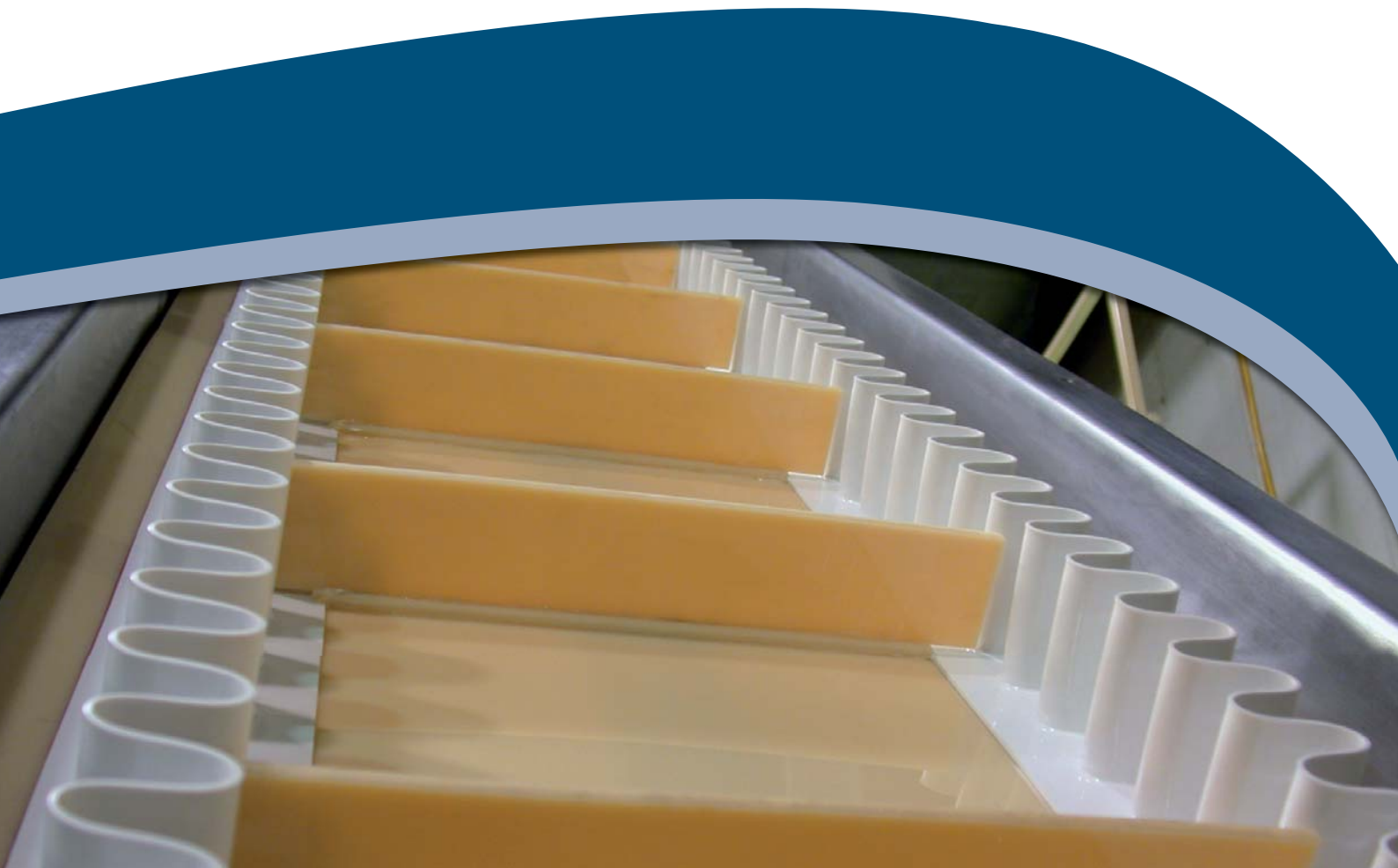

The Next Step in Belting

Sidewalls

Volta Sidewalls are manufactured from our unique homogenous TPE materials and are especially designed to be fully compatible with all our flat belts. In addition, our sidewalls are compatible with most PU belts and some PVC belts. Welding our sidewalls is very easy and keeps the belt surface smooth, boosting the hygiene levels. This product line includes three color sidewalls for the different industries - white, green and blue. Because of its homogenous characteristics, Volta sidewalls are highly resistant to cutting, tearing, oils and abrasion. Our white and blue sidewalls conform to the highest international standards for food contact.

Reasons to Use Volta Sidewalls:

- Fully compatible with all Volta flat belts
- Compatible with most PU and some PVC belts
- High resistance to cutting, tearing, oils and abrasion
- White (W) and Blue (MB) Sidewalls are USDA / FDA / 3ADairy approved
- Long and reliable service life

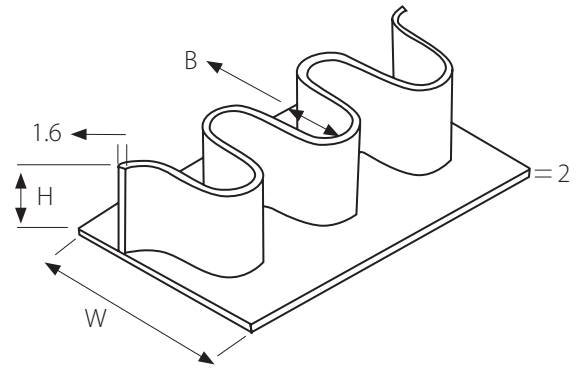

The techniques for welding our Sidewalls on to the base belt remain basically unchanged. However, we recommend that you make several welding practice runs to acquaint yourself with the way the material responds.

If you have any technical questions or would like to receive more information, please contact your local Volta distributor.

Type	SW - 20		SW- 30		SW- 40		SW- 50		SW- 60		SW- 80		SW -100	
	mm	inch	mm	inch	mm	inch	mm	inch	mm	inch	mm	inch	mm	inch
Height : H	20	13/16	30	1 1/4	40	1 1/2	50	2	60	2 3/8	80	3 1/8	100	4
Base Width: W	40	1 1/2	40	1 1/2	40	1 1/2	70	2 3/4	70	2 3/4	70	2 3/4	70	2 3/4
Wall Width: B	18	5/7	18	5/7	18	5/7	34	1 5/16	34	1 5/16	34	1 5/16	34	1 5/16
Minimum Pulley														
Belt Tickness	mm	inch	mm	inch	mm	inch	mm	inch	mm	inch	mm	inch	mm	inch
2	80	3 1/4	80	3 1/4	90	3 5/8	NR	NR	NR	NR	NR	NR	NR	NR
2.5	80	3 1/4	80	3 1/4	90	3 5/8	100	4	110	4 1/4	NR	NR	NR	NR
3	90	3 4/8	90	3 5/8	100	4	110	4 1/4	120	4 3/4	150	6	200	8
3.2	90	3 4/8	90	3 5/8	100	4	110	4 1/4	120	4 3/4	150	6	200	8
4	100	3 5/8	100	4	120	4 3/4	120	4 3/4	130	5 1/8	150	6	200	8
5	110	4 1/4	110	4 1/4	120	4 3/4	120	4 3/4	130	5 1/8	150	6	200	8



VOLTA Belting Technology Ltd.

USA

Tel: +1 973 276 7905
 Fax: +1 973 276 7908
 Tol Free: 1-877-VOLTAUS

EUROPE

Tel: +31-546-580166
 Fax: +31-546-579508

www.voltabelting.com - e-mail: sales@voltabelting.com