

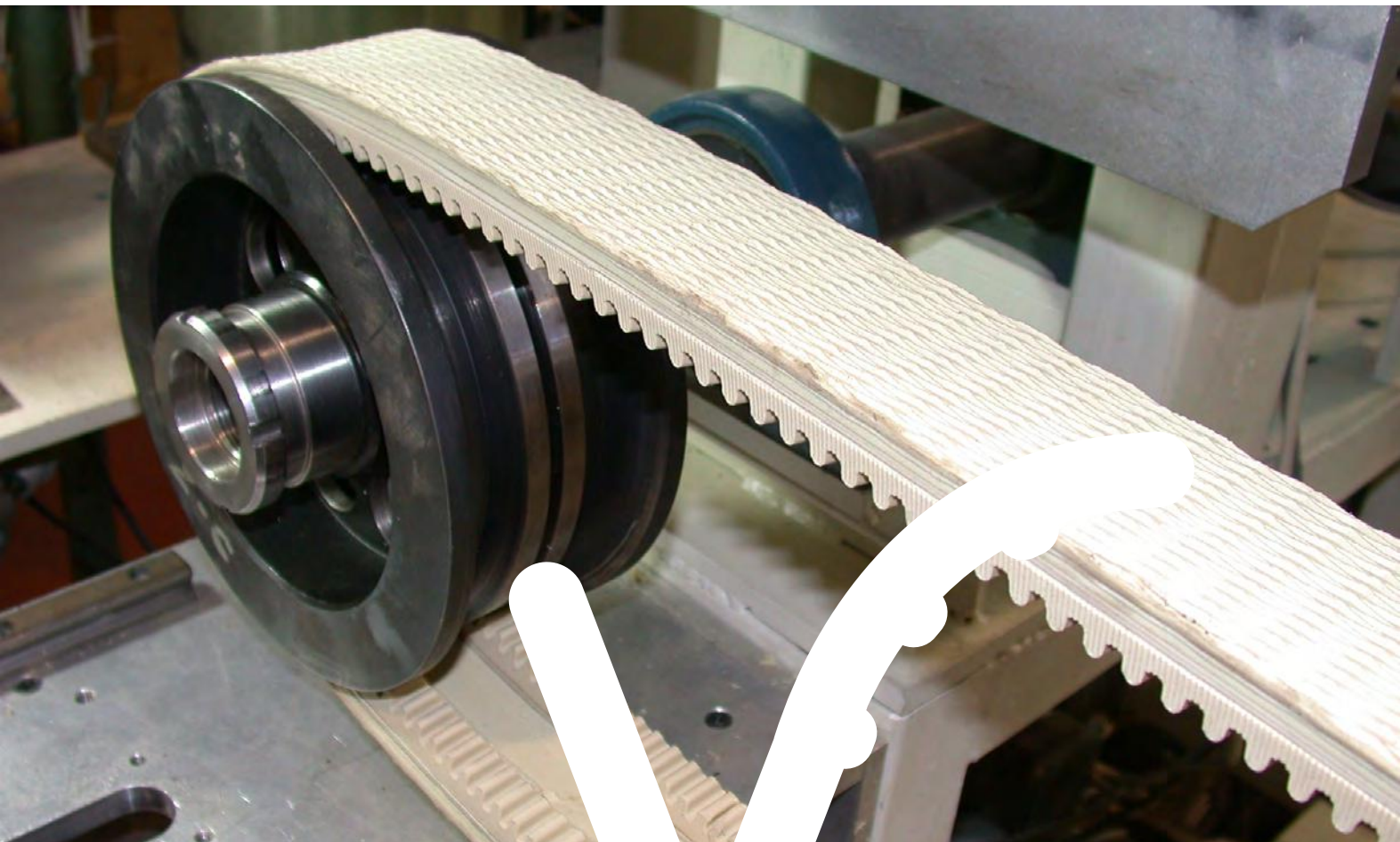

The Next Step in Belting



Wood Industry
Conveying Solutions

Wood processing machinery performs many unique and difficult applications. Volta Belting Technology has the product range, experience and technologies to provide solutions for these machine-based applications.

The product range includes:

- ✓ 1524 mm/60" wide flat belts on cutting & gluing lines and for transporting in the wood industry.
- ✓ White Volta Power® Transmission belts for applications requiring high grip and non-marking characteristics.
- ✓ Belt coatings for flat wide belts, profiles and timing belts.
- ✓ Belts for specific use machines such as edge banders and tenoners.
- ✓ Roller coating sleeves.

Volta Power® in the Wood Industry

The Volta Power® product line includes belts specially designed for wood processing machinery produced from white colored Thermoplastic Rubber (TPR) that combines the performance properties of Thermo set rubber with the capabilities of the Thermoplastics' processing equipment. Compared to rubber, TPR gives a better quality final product with superior dimensional accuracy.



Our unique computerized production system enables us to manufacture standard or non-standard power transmission belts in any length up to 70 meters without minimum quantities and shipping within days.

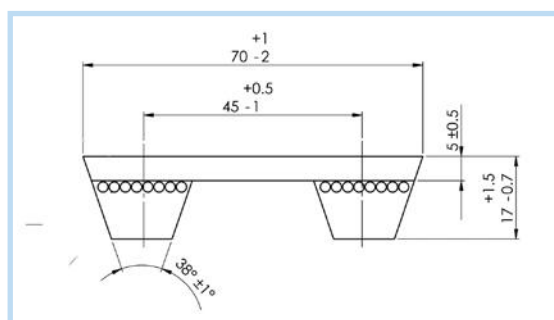
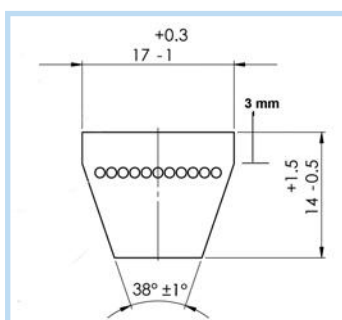

Typical (Machine) Applications

Double-end tenoners and edge banders are designed for high-speed processing of panel shaped workpieces such as:

- direct coated panels
- cork
- MDF
- plywood
- hard foam
- plastics
- core board
- post forming or cement-bonded fiber
- solid wood

This work requires a belt that will firmly grip any material used without marking the final product.

Typical Machine

- HOMAG
- STEFANI
- BIESSE
- IDM
- IMA
- CELASCHI
- OLZ-HER
- NARDELLO



Volta Power® for the Wood Industry Products



Classical Power Belt with Smooth Top

Sections	A	B	20	C	25	D
Width (~)	13	17	20	22	25	32
Height (~)	11	14	15	17	19	23
Min. Pulley (mm)*	80	140	180	200	280	400



Classical Power Belt with ITO (Impression Top Oval) & Waffle Top

Sections	A	B	20	C	25	D
Width (~)	13	17	20	22	25	32
Height (~)	11	14	15	17	19	23
Min. Pulley (mm)*	80	140	180	200	280	400

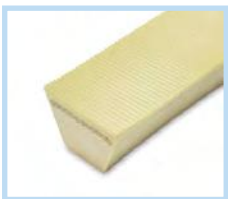

Classical Power Belt with Roof Top

Sections	D/32
Width (~)	32
Height (~)	24
Min. Pulley (mm)*	400



Banded Belt with Waffle & Smooth Top

Volta Power® produces a line of special white banded belts. The belts are available with smooth, soft top (PKR0) or with waffle top (PKR2). These belts are designed to be used on processing machinery requiring a belt that is non-marking and has high grip. In addition, the belt provides excellent strength and carrying capacity.

The benefits of the banded belts are:

- increased transmission efficiency
- reduced maintenance cost
- eliminates belt twisting and reduces whipping
- ensures even belt tension

Volta Power® for the Wood Industry Products



Special Dimension Belts with Waffle Top

Dimensions	48x15	50x20
Min. Pulley (mm)*	140	200



Special Banded Belt

Dimensions	62x18	67x17	70x17	75x17
Min. Pulley (mm)*	200	200	200	200

Classical, narrow, banded and conveyor belts are also available in white.

Flat Belts in the Wood Industry

The belts made for Industrial Applications are manufactured from Thermoplastic Elastomer (TPE) material with unique homogeneous characteristics. These belts are most suitable for conveying wood and are available in a wide range of colors, thicknesses, hardnesses and surface textures. Quality thermo-welded fabrications are custom-made to suit your specific needs perfectly. Standard Belt Width = 1524mm /60”.

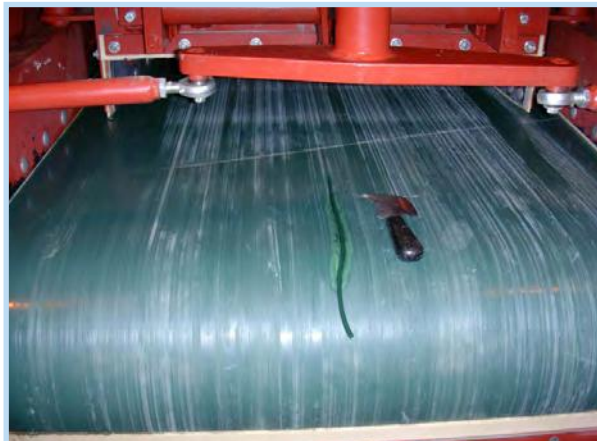

The product range includes:

- ✓ High carrying capacity with excellent grip.
- ✓ Soft, non-marking belts treat the product conveyed with extreme care.
- ✓ The belts absorb the impact of the falling products well ensuring long life.
- ✓ Resistant to chemical action from moisture, paints and other compounds and resistant to glues adhering to the belt surface.
- ✓ The belt materials' flexible character is highly resistant to abrasion and inhibits surface cuts from spreading.
- ✓ Homogeneous smooth surface does not crumble or crack (as seen in rubber belting).
- ✓ Reinforced - bottom belts used to prevent elongation on very long conveyors.
- ✓ Quick and easy to repair and to make endless with Volta thermo welding tools.

Classical Power Belt with Smooth Top

Belt Type	Color	Shore Hardness	Thickness mm	Industry	Application	Reinforced	Non-Marking	Grip	Resists Paints & Glues	Quick Splice & Repair	Resistant to Abrasion
FRL	Brown	80A	2	Wood Flooring	Dimpter of Graycon Sorters	✓	✓	high	✓	✓	✓
			3	Melamine	Transfers						
				Cabinet Manufacture	Dimpter Sorters						
5	Plywood	Skinner Saws, Trim Saws, Jumper Belts, Inclines									
FRZ	Green 05	95A/46D	4	Wood Flooring	Dimpter of Graycon Sorters	✓	✓	medium	✓	✓	✓
				Plywood	Putty Lines						
				Cabinet Manufacture	Dimpter Sorters						
3	Plywood	Veneer Stackers, Jumper Belts, Putty Lines									
FRG	Grey	95A/46D	2	Plywood	Set of Narrow Spaced Belts	✓	✓	medium	✓	✓	✓
			3		Alignment Belt						
FK	Green 17	59D	3	Sawmill	Cut Board Transfer Belts	✓	✓	low	✓	✓	✓
			4	Raw Timber	Feeding Belt						
FRPZ	Green 05	86A	3	Floor Lamination	Feeding Belt	✓	✓	high	✓	✓	✓

Roller Coating Sleeves

Volta Sleeves have an abrasion resistant, soft, non-marking surface that is ideal for coating rollers. Using Volta proprietary tools, the sleeves are easily mounted without lubricants or glues. Sleeves are available with a smooth surface and in dimensions from 27 mm O.D. to 95 mm O.D.

Contact your local distributor for further details regarding the dimensions and availability of Ribbed Sleeves.



Belt Coatings

A wide range of heat-welded coatings can be applied to achieve extra grip and added protection against forceful impact of falling wood.

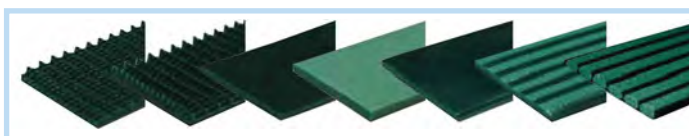

Volta Products in the Wood Industry

Product Types	Non- marking	Resistant to abrasion	Resistant to paints and glue	High grip	Dimensional stability	Hard material	Soft material	Surface texture
PU V belts	✓	✓	✓	✓	✓	✓	✓	
PU Round belts	✓	✓	✓	✓	✓	✓	✓	
A * section	✓	✓	✓	✓	✓	✓		
B * section	✓	✓	✓	✓	✓	✓		
C * section	✓	✓	✓	✓	✓	✓		
D * section	✓	✓	✓	✓	✓	✓		
Double-C	✓	✓	✓	✓	✓	✓		
48x15	✓	✓	✓	✓	✓	✓		
50x20	✓	✓	✓	✓	✓	✓		
SP-2x20 (67x17) *	✓	✓	✓	✓	✓	✓		
SP-2C (70x17) *	✓	✓	✓	✓	✓	✓		
PU Waffle	✓	✓	✓	✓	✓		✓	
FSTF	✓			✓	✓		✓	
FST	✓		✓	✓	✓		✓	
FSTF-ST strips	✓			✓	✓		✓	✓
Machine tapes (SM)	✓		✓	✓	✓		✓	
Sleeves, Standard Smooth	✓	✓	✓	✓	✓		✓	
Sleeves, Special Ribbed**	✓	✓	✓	✓	✓		✓	✓

* Available with a standard smooth top PKR0 and Waffle top PKR2 patterns.

Wood Industry



Edge Bander

Belt Section: SP - 2C
Quantity In Machine: 1



Post forming

Belt Section: SP - 2C
Quantity In Machine: 1



Wood Processing

Belt Section: SP - 2C
Quantity In Machine: 1



Tenoners

Belt Section: D - PKR0
Quantity In Machine: 2



Tenoners

Belt Section: D - PKR0
Quantity In Machine: 2



Edge Bander

Belt Section: 48x15
Quantity In Machine: 1

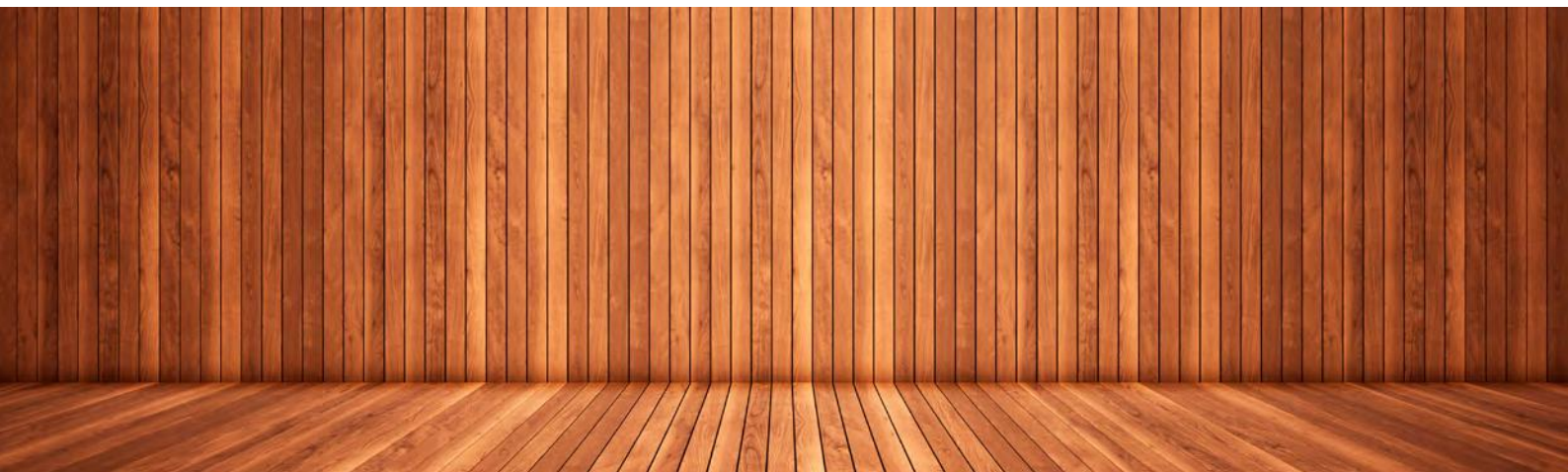

volta™
Belting Technology

CORPORATE
HEADQUARTERS
Sales and Manufacturing
sales@voltabelting.com

USA
Tel. +1 973 276 7905
Toll Free, 1-877-VOLTAUS
voltaus@voltabelting.com

EUROPE
Tel. +31 546 580166
voltaeu@voltabelting.com

www.voltabelting.com

Volta Belting makes no warranty with respect to any of its products for a particular purpose. See Volta General Terms and Conditions.

Copyright© Volta Belting Technology Ltd.
9CAT003EN00 - Ver. D - March 2021

now-branding.co.il