

Automobile assembly line conveyor belts

AutoBelts - FRL-11

Volta Belting manufactures custom-made conveyor belts used in the automotive industry, suited to a variety of processes in car production: stamping, assembly, paintwork and more.

Volta Belting advantages

- | Truly endless belts with no weak joint prone to failure.
- | Embedded Aramid cords enable the belts to convey heavy loads.
- | Dense thermoplastic layers resist wear and tear and give many times the working life compared to other available products for this use.
- | Superior resistance to paint, solvents and oils. will not rot or release particles to contaminate paintwork.
- | Belt lengths up to 50 meters/164 ft. and more, truly endless with no splice.
- | Minimal elongation due to the Aramid cords which ensures continuity in production without frequent adjustment of belt tensioning.

Volta Belting Technology Ltd. has been a world leader in the manufacture of Thermoplastic Elastomer (TPE) belting and profiles for over 50 years. Volta has facilities in the Netherlands and USA - NJ, offering our belts in over 50 countries around the world.

AutoBelts FRL-11

Materials	Bottom: Volta L Brown / Top: Volta FL Brown
Hardness	Bottom: 80A Shore / Top: 76A Shore
Temperature Range*	-5°C to 50°C / 23°F to 120°F
Coefficient of Friction	Bottom: Steel: 0.2 Top: Steel: 1.0
Belt Thickness	10.8mm
Maximum Belt Width	400mm / 15.75"
Minimum Pulley Diameter: Temp ≥ 5°C /41°F	120mm/ 4.8"
Maximum Pull Force: • Belt width 55mm • Belt width 80mm	4800 Kg / 10560 Lbs 7800 Kg / 17160 Lbs
Pull Force at Pretension of 1% • Belt width 55mm • Belt width 80mm	730 Kg / 1606 Lbs 1095 Kg / 2409 Lbs

Note: **Pull Force** - Relates to Steel Pulleys. For Rubber lagged pulleys/drums please contact your Volta representative.
* **Temperature Range** - for lower or higher temperatures , please contact your Volta representative.

Belt Components

Top layer

Volta FL material
High grip

Tensile Cords

Truly endless with no splice

Bottom Layer

Volta FRL material
Fabric layer for reduced friction

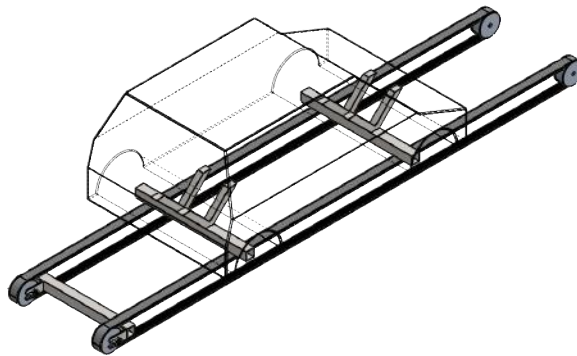
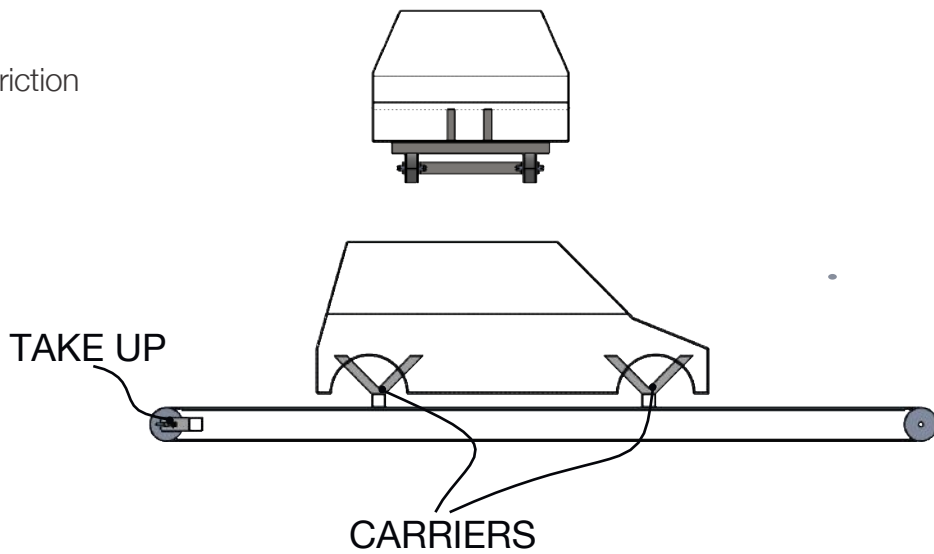
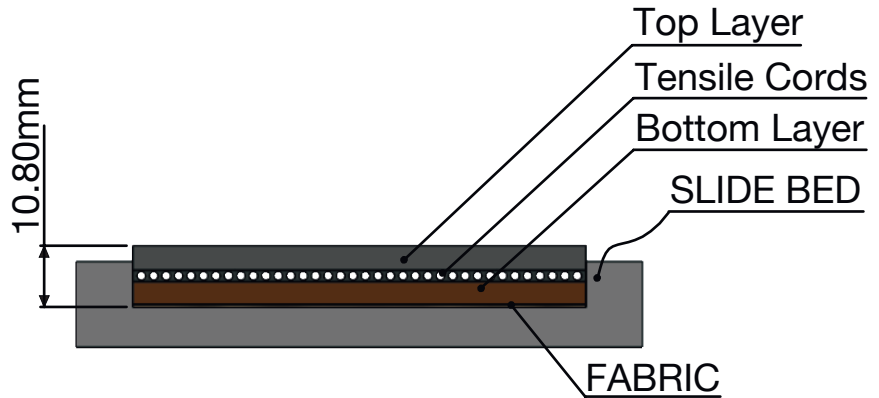

volta™
Belting Technology

voltabelting.com

CORPORATE
HEADQUARTERS
Sales and Manufacturing
sales@voltabelting.com

USA
Tel. +1 973 276 7905
Toll Free, 1-877-VOLTAUS
voltaus@voltabelting.com

EUROPE
Tel. +31 546 580166
voltaeu@voltabelting.com

Volta Belting makes no warranty with respect to any of its products for a particular purpose. See Volta General Terms and Conditions.

Copyright© Volta Belting Technology Ltd.
CAT517EN00 - Ver. B - March.2020